

DO NOT SCALE FROM THIS PRINT

FIG 1  
(FFMD-10-D-XX.XX-01-X SHOWN)

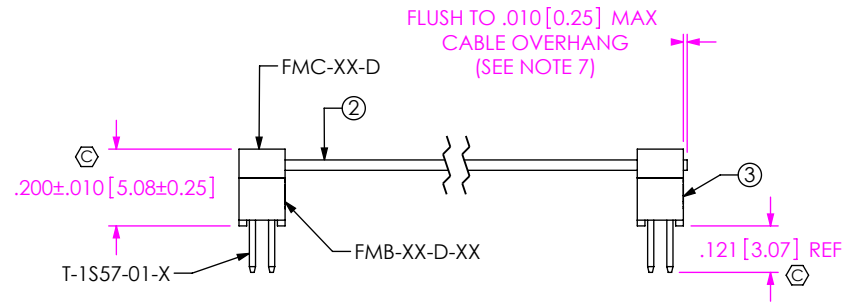
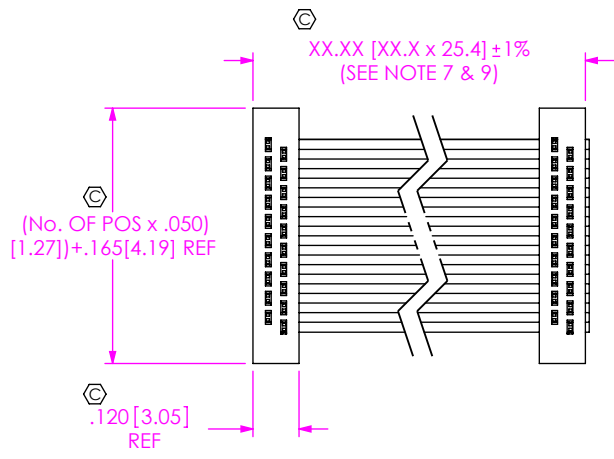

FFMD-XX-X-XX.XX-01-X-X-XXX

No OF POSITIONS  
-03 TO -25

END ASSEMBLY  
-D: DOUBLE END  
-S: SINGLE END  
\*-T: TRANSFER END

ASSEMBLY LENGTH  
(2.00 [50.8] MINIMUM)

LEAD STYLE

PLATING OPTIONS  
LEAVE BLANK FOR STANDARD  
(USE T-1S57-01-T AND C-67-L)  
-L: SELECTIVE LIGHT GOLD  
(USE T-1S57-01-L AND C-67-L)  
-F: FLASH SELECTIVE GOLD  
(USE T-1S57-01-F AND C-67-F)  
-S: SELECTIVE GOLD  
(USE T-1S57-01-S AND C-67-S)

OPTION

-RW: REVERSE WIRING  
-BXX: BREAKOUT OPTION  
-O: OUTSIDE REVERSED  
-M: MIDDLE REVERSED  
-R: REVERSE  
-DXX: DAISY CHAIN (MINIMUM 2.00 [50.8], 1.00 [25.4] INCREMENTS)  
-SR: STRAIN RELIEF (NOT AVAILABLE WITH -O, -M, -R, -DXX OR -BXX) (SOLD AS ASSEMBLIES ONLY)

TRANSFER OPTION

-N: SOCKET HAS NOTCH POLARIZATION (-T END ASSEMBLY ONLY) (LEAVE BLANK FOR -S AND -D END OPTIONS) (NOT AVAILABLE ON POSITIONS -02 THRU -04)

\*16-25 POS TRANSFER END STRAIN RELIEF NOT RELEASED FOR PRODUCTION

FIG 2  
(FFMD-10-S-XX.XX-01-X SHOWN)  
(SAME AS FIG 1, DIFFERENT AS SHOWN)

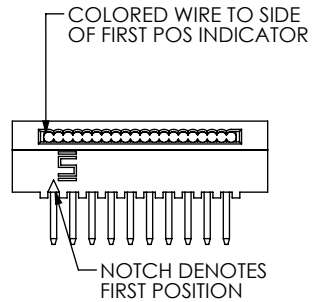
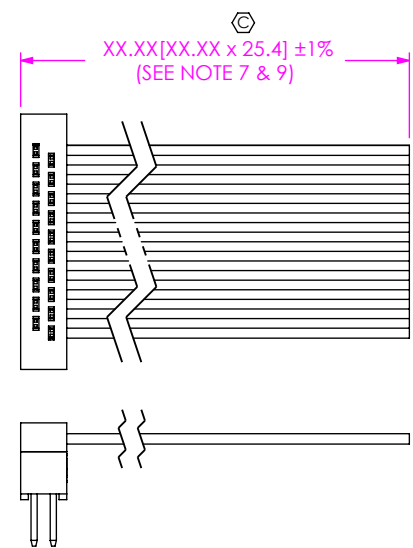

TABLE 1	
ITEM #	PART
1	FFSD-XX-XX-X-N
2	CB-XX-30-7
3	FFMD-XX-XX-X-XX
4	FFMD-XX-01-X-SR
5	FFSR-XX-01
6	FFSR-XX-02
7	FFSD-XX-XX-X-N-SR1
8	FFSD-XX-XX-X-N-SR2

- NOTES:
- ① REPRESENTS A CRITICAL DIMENSION.
  - FFSD ASSEMBLY TO BE USED FOR TRANSFER END ONLY.
  - ALL ASSEMBLIES TO BE 100% ELECTRONICALLY TESTED FOR SHORTS AND OPENS.
  - ALL ASSEMBLIES TO BE 100% HI-POT TESTED AT 630V.
  - STRAIN RELIEF TO WITHSTAND 5LB[22N] STRAIGHT PULL.
  - FFMD CABLE ASSEMBLIES ARE LEAD FREE.
  - WHEN CUTTING CABLE TO LENGTH, CONDUCTORS SHOULD NOT EXTEND PAST THE CABLE INSULATION, EXTENDING LESS THAN 25% OF CABLE THICKNESS ON CONSECUTIVE AND LESS THAN 50% OF CABLE THICKNESS ON NON-CONSECUTIVE STRANDS IS CONSIDERED A PROCESS INDICATOR.
  - REFERENCE FFMD-XX-XX-X-XX (AND FFSD-XX-XX-X-N-XX FOR -T OPTION) DRAWING FOR CONNECTOR ASSEMBLY DIMENSIONS AND ITS REQUIREMENTS.
  - FOR LENGTHS LESS THAN 12.5" TOLERANCE SHALL BE +/- .125, ALL OTHER LENGTHS SHALL BE +/- 1%.
  - PACKAGE PER IDC STYLE CABLE SECTION OF PACKAGING MANUAL.

UNLESS OTHERWISE SPECIFIED, DIMENSIONS ARE IN INCHES.  
TOLERANCES ARE:  
DECIMALS ANGLES  
.XX: ±.01 [.3] 2°  
.XXX: ±.005 [.13]  
.XXXX: ±.0020 [.051]

PROPRIETARY NOTE  
THIS DOCUMENT CONTAINS CONFIDENTIAL AND PROPRIETARY INFORMATION AND ALL DESIGN, MANUFACTURING, REPRODUCTION, USE, PATENT RIGHTS AND SALES RIGHTS ARE EXPRESSLY RESERVED BY SAMTEC, INC. THIS DOCUMENT SHALL NOT BE DISCLOSED, IN WHOLE OR PART, TO ANY UNAUTHORIZED PERSON OR ENTITY NOR REPRODUCED, TRANSFERRED OR INCORPORATED IN ANY OTHER PROJECT IN ANY MANNER WITHOUT THE EXPRESS WRITTEN CONSENT OF SAMTEC, INC.



520 PARK EAST BLVD, NEW ALBANY, IN 47150  
PHONE: 812-944-6733 FAX: 812-948-5047  
e-Mail: info@SAMTEC.com code: 55322

MATERIAL: DO NOT SCALE DRAWING SHEET SCALE: 2:1  
INSULATOR: PBT, COLOR: BLACK  
CONTACT: BeCu  
TERMINAL: PHOS BRONZE  
WIRE: 30 AWG, 7/38, TINNED, STRANDED WITH PVC INSULATOR

DESCRIPTION:  
.050 X .050 DOUBLE ROW MALE IDC CABLE ASSEMBLY

DWG. NO.  
FFMD-XX-X-XX.XX-01-X-X-XXX

BY: T NEWTON 02/15/2008 SHEET 1 OF 6

**FIG 3**  
(FFMD-10-D-XX.XX-01-X-SR SHOWN)  
(SAME AS FIG 1, DIFFERENT AS SHOWN)

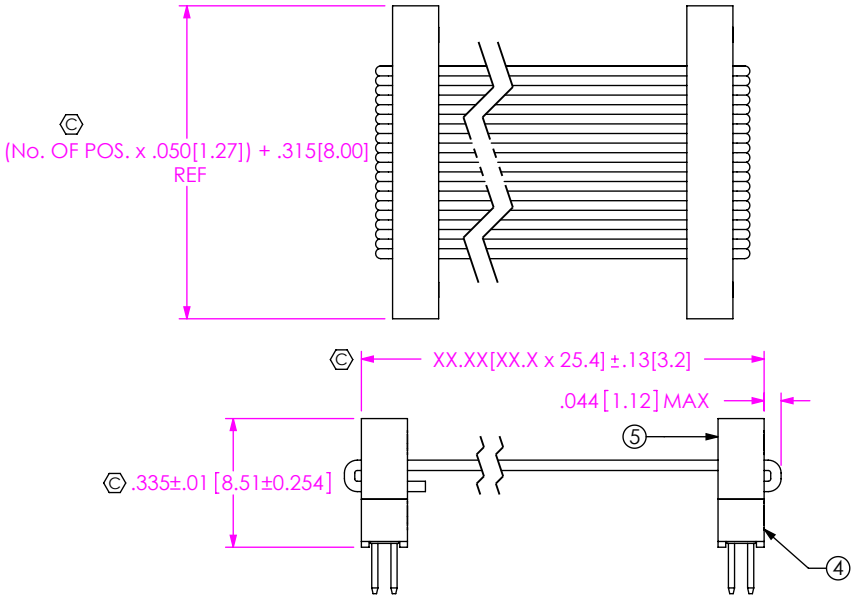

**FIG 4**  
(FFMD-10-X-XX.XX-01-X-RW SHOWN)  
(SAME AS FIG 1, DIFFERENT AS SHOWN)

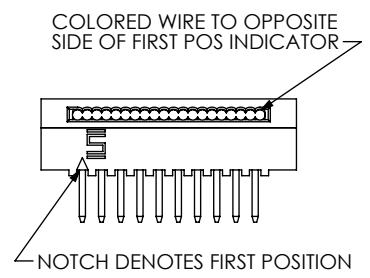

**FIG 5**  
(FFMD-10-X-XX.XX-01-X-N SHOWN)  
(SAME AS FIG 1 AND FIG 6, DIFFERENT AS SHOWN)  
(FOR -T ONLY)  
(IF OPTION IS SPECIFIED USE FFSD-XX-01-X-N)

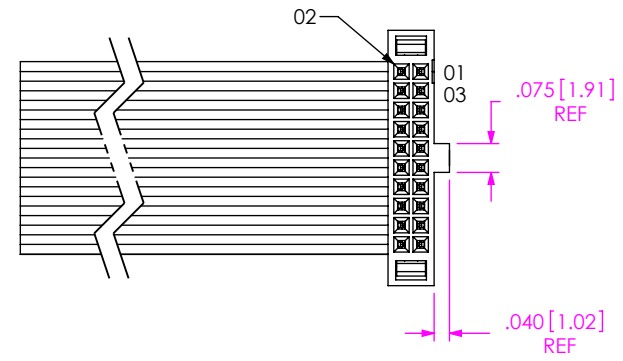

**FIG 6**  
(FFMD-10-T-XX.XX-01-X-N SHOWN)  
(SAME AS FIG 1, DIFFERENT AS SHOWN)

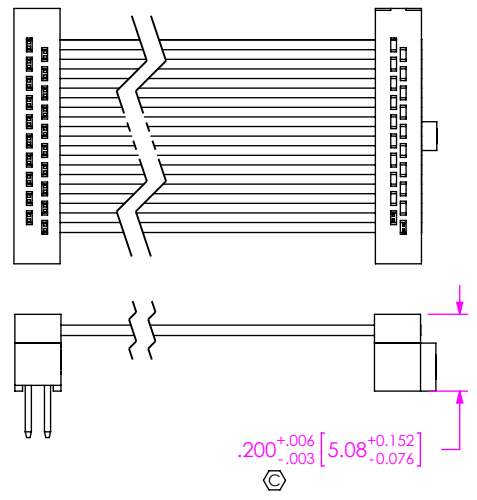

**FIG 7**  
(FFMD-10-T-XX.XX-01-X-N-B05 SHOWN)  
(SAME AS FIG 1 AND FIG 6, DIFFERENT AS SHOWN)  
"XX" = NO. OF CONDUCTORS PER ROW  
BROKEN OUT FROM THE FIRST POSITION

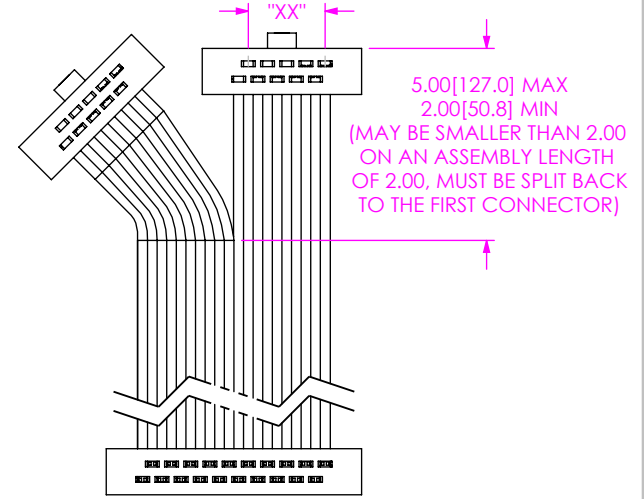

**IN-PROCESS 1**  
-SR ONLY

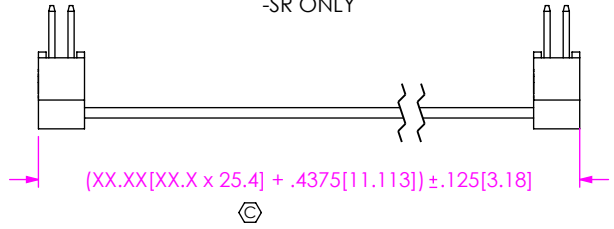

**IN-PROCESS 2**  
-SR ONLY

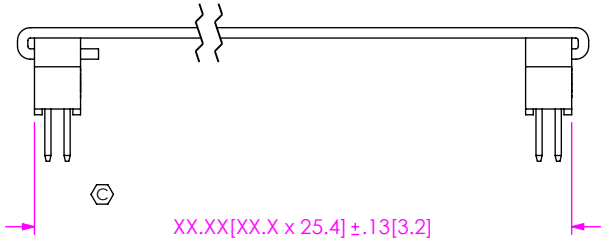

**PROPRIETARY NOTE**

THIS DOCUMENT CONTAINS CONFIDENTIAL AND PROPRIETARY INFORMATION AND ALL DESIGN, MANUFACTURING, REPRODUCTION, USE, PATENT RIGHTS AND SALES RIGHTS ARE EXPRESSLY RESERVED BY SAMTEC, INC. THIS DOCUMENT SHALL NOT BE DISCLOSED, IN WHOLE OR PART, TO ANY UNAUTHORIZED PERSON OR ENTITY NOR REPRODUCED, TRANSFERRED OR INCORPORATED IN ANY OTHER PROJECT IN ANY MANNER WITHOUT THE EXPRESS WRITTEN CONSENT OF SAMTEC, INC.

DO NOT SCALE DRAWING

SHEET SCALE: 2:1



520 PARK EAST BLVD, NEW ALBANY, IN 47150  
PHONE: 812-944-6733 FAX: 812-948-5047  
e-Mail: info@SAMTEC.com code: 55322

DESCRIPTION:  
.050 X .050 DOUBLE ROW MALE IDC CABLE ASSEMBLY

DWG. NO.  
**FFMD-XX-X-XX.XX-01-X-X-XXX**

BY: T NEWTON 02/15/2008 SHEET 2 OF 6

FIG 8

(FFMD-10-D-XX.XX-01-X-DXX-O SHOWN)  
 (SAME AS FIG 1, DIFFERENT AS SHOWN)  
 (2.00[50.8] MINIMUM LENGTH, 1.00[25.4] INCREMENTS)  
 (NOT AVAILABLE WITH -R OR -M OPTIONS)

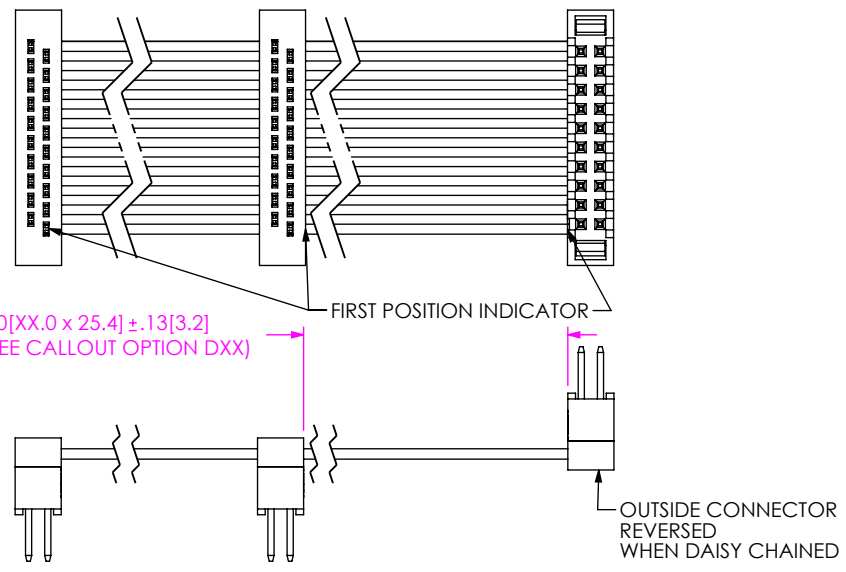

FIG 9

(FFMD-10-D-XX.XX-01-X-DXX-M SHOWN)  
 (SAME AS FIG 1, DIFFERENT AS SHOWN)  
 (2.00[50.8] MINIMUM LENGTH, 1.00[25.4] INCREMENTS)  
 (NOT AVAILABLE WITH -R OR -O OPTIONS)

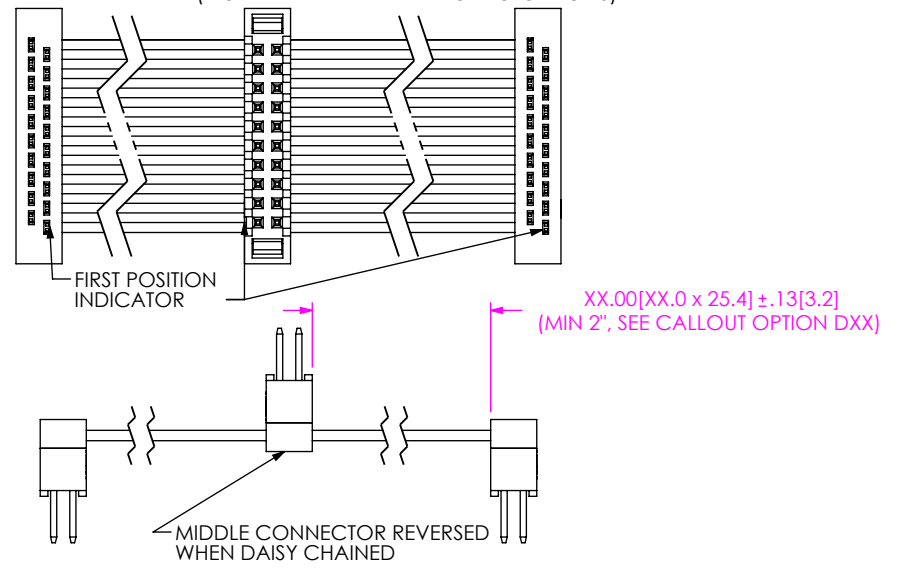

FIG 10

(FFMD-10-T-XX.XX-01-X-N-DXX-O SHOWN)  
 (SAME AS FIG 1 AND FIG 6, DIFFERENT AS SHOWN)  
 (2.00[50.8] MINIMUM LENGTH, 1.00[25.4] INCREMENTS)  
 (NOT AVAILABLE WITH -R OR -M OPTIONS)

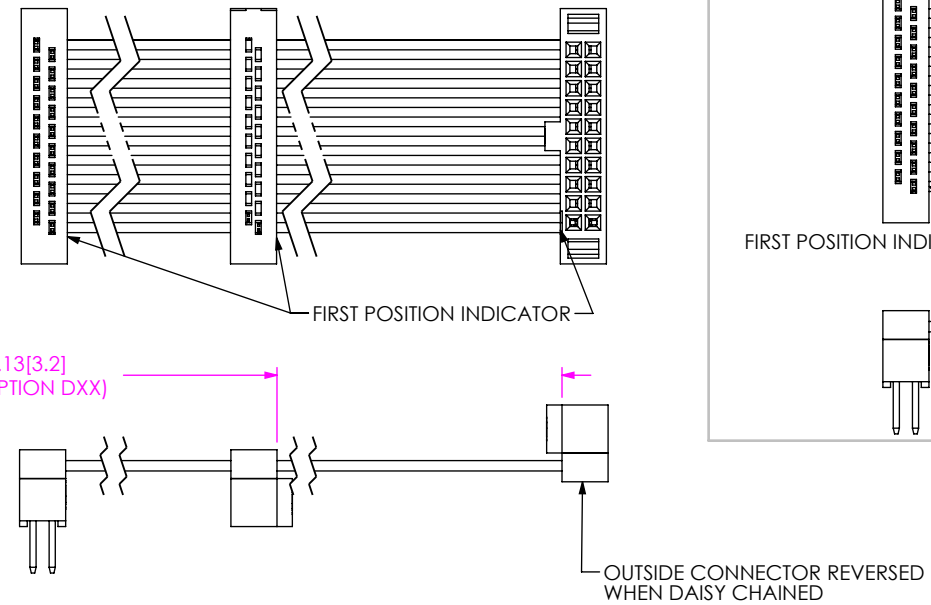
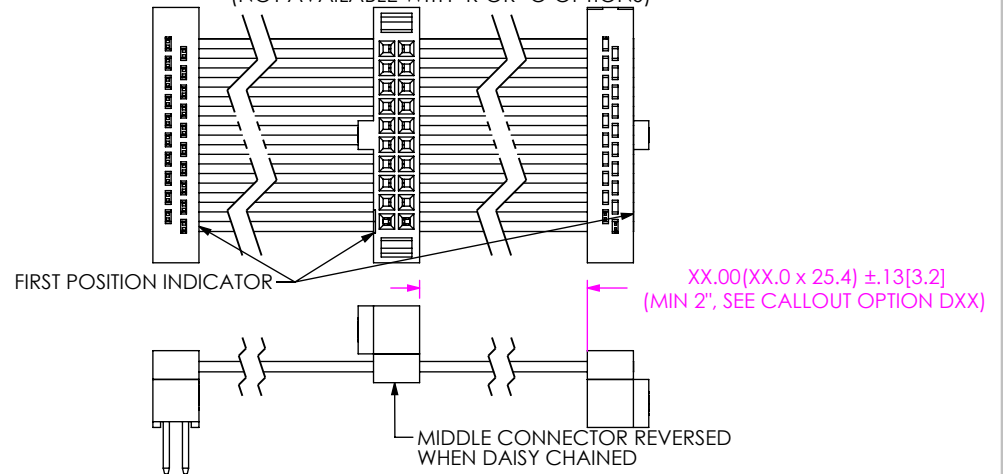

FIG 11

(FFMD-10-T-XX.XX-01-X-N-DXX-M SHOWN)  
 (SAME AS FIG 1 AND FIG 6, DIFFERENT AS SHOWN)  
 (2.00[50.8] MINIMUM LENGTH, 1.00[25.4] INCREMENTS)  
 (NOT AVAILABLE WITH -R OR -O OPTIONS)



**PROPRIETARY NOTE**  
 THIS DOCUMENT CONTAINS CONFIDENTIAL AND PROPRIETARY INFORMATION AND ALL DESIGN, MANUFACTURING, REPRODUCTION, USE, PATENT RIGHTS AND SALES RIGHTS ARE EXPRESSLY RESERVED BY SAMTEC, INC. THIS DOCUMENT SHALL NOT BE DISCLOSED, IN WHOLE OR PART, TO ANY UNAUTHORIZED PERSON OR ENTITY NOR REPRODUCED, TRANSFERRED OR INCORPORATED IN ANY OTHER PROJECT IN ANY MANNER WITHOUT THE EXPRESS WRITTEN CONSENT OF SAMTEC, INC.

**samtec**  
 520 PARK EAST BLVD, NEW ALBANY, IN 47150  
 PHONE: 812-944-6733 FAX: 812-948-5047  
 e-Mail: info@SAMTEC.com code: 55322

DO NOT SCALE DRAWING  
 SHEET SCALE: 2:1

DESCRIPTION:  
 .050 X .050 DOUBLE ROW MALE IDC CABLE ASSEMBLY  
 DWG. NO.  
**FFMD-XX-X-XX.XX-01-X-X-XXX**  
 BY: T NEWTON 02/15/2008 SHEET 3 OF 6

FIG 12

(FFMD-10-D-XX.XX-01-DXX-R SHOWN)  
 (SAME AS FIG 1, DIFFERENT AS SHOWN)  
 (2.00[50.8] MINIMUM LENGTH, 1.00[25.4] INCREMENTS)  
 (NOT AVAILABLE WITH -M OR -O OPTIONS)

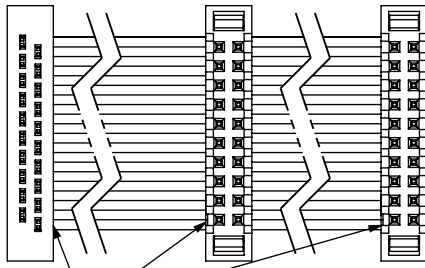

FIRST POSITION INDICATOR

BOTH CONNECTORS REVERSED WHEN DAISY CHAINED

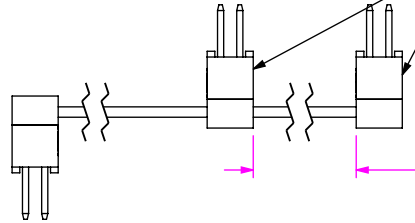

$XX.00[XX.0 \times 25.4] \pm .13[3.2]$   
 (MIN 2", SEE CALLOUT OPTION DXX)

FIG 13

(FFMD-10-D-XX.XX-01-X-DXX)  
 (SAME AS FIG 1, DIFFERENT AS SHOWN)  
 (2.00[50.8] MINIMUM LENGTH, 1.00[25.4] INCREMENTS)

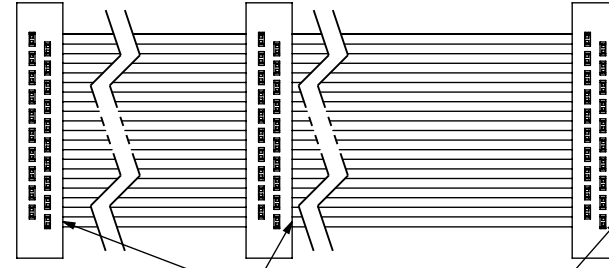

FIRST POSITION INDICATOR

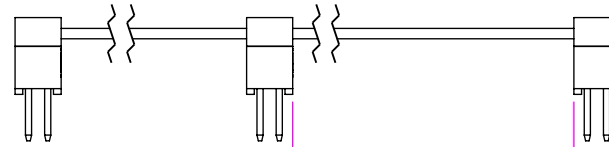

$XX.00[XX.0 \times 25.4] \pm .13[3.2]$   
 (MIN 2", SEE CALLOUT OPTION DXX)

FIG 14

(FFMD-10-T-XX.XX-01-X-N-DXX-R SHOWN)  
 (SAME AS FIG 1 AND FIG 6, DIFFERENT AS SHOWN)  
 (2.00[50.8] MINIMUM LENGTH, 1.00[25.4] INCREMENTS)  
 (NOT AVAILABLE WITH -M OR -O OPTIONS)

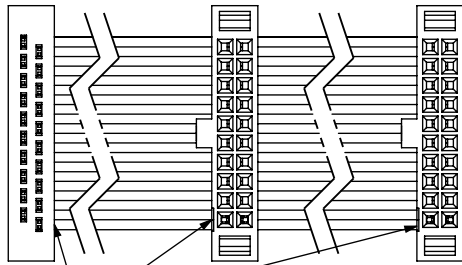

FIRST POSITION INDICATOR

BOTH CONNECTORS REVERSED WHEN DAISY CHAINED

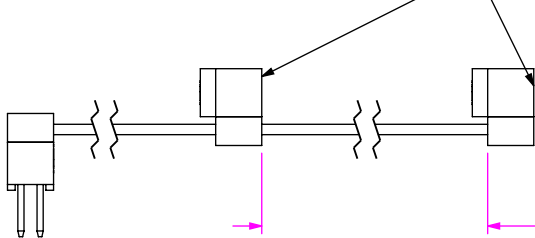

$XX.00[XX.0 \times 25.4] \pm .13[3.2]$   
 (MIN 2", SEE CALLOUT OPTION DXX)

FIG 15

(FFMD-10-T-XX.XX-01-X-N-DXX)  
 (SAME AS FIG 1 AND FIG 6, DIFFERENT AS SHOWN)  
 (2.00[50.8] MINIMUM LENGTH, 1.00[25.4] INCREMENTS)

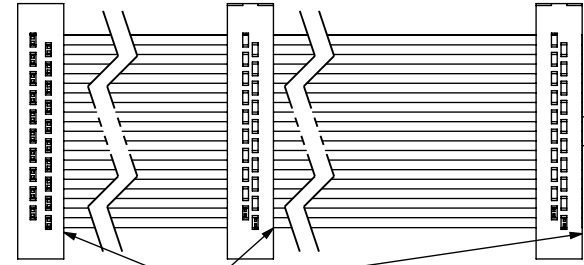

FIRST POSITION INDICATOR

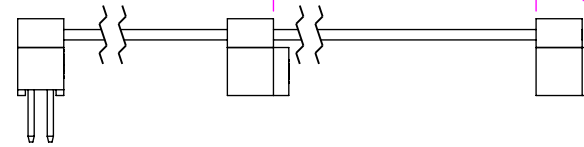

$XX.00[XX.0 \times 25.4] \pm .13[3.2]$   
 (MIN 2", SEE CALLOUT OPTION DXX)

PROPRIETARY NOTE

THIS DOCUMENT CONTAINS CONFIDENTIAL AND PROPRIETARY INFORMATION AND ALL DESIGN, MANUFACTURING, REPRODUCTION, USE, PATENT RIGHTS AND SALES RIGHTS ARE EXPRESSLY RESERVED BY SAMTEC, INC. THIS DOCUMENT SHALL NOT BE DISCLOSED, IN WHOLE OR PART, TO ANY UNAUTHORIZED PERSON OR ENTITY NOR REPRODUCED, TRANSFERRED OR INCORPORATED IN ANY OTHER PROJECT IN ANY MANNER WITHOUT THE EXPRESS WRITTEN CONSENT OF SAMTEC, INC.

DO NOT SCALE DRAWING

SHEET SCALE: 2:1



520 PARK EAST BLVD, NEW ALBANY, IN 47150  
 PHONE: 812-944-6733 FAX: 812-948-5047  
 e-Mail: info@SAMTEC.com code: 55322

DESCRIPTION:  
 .050 X .050 DOUBLE ROW MALE IDC CABLE ASSEMBLY

DWG. NO.  
**FFMD-XX-X-XX.XX-01-X-X-XXX**

BY: T NEWTON 02/15/2008 SHEET 4 OF 6

**FIG 16**  
 (FFMD-10-T-XX.XX-01-X-N-SR SHOWN)  
 (SAME AS FIG 1 AND FIG 3, DIFFERENT AS SHOWN)  
 (FOR POSITIONS 2-15 ONLY)

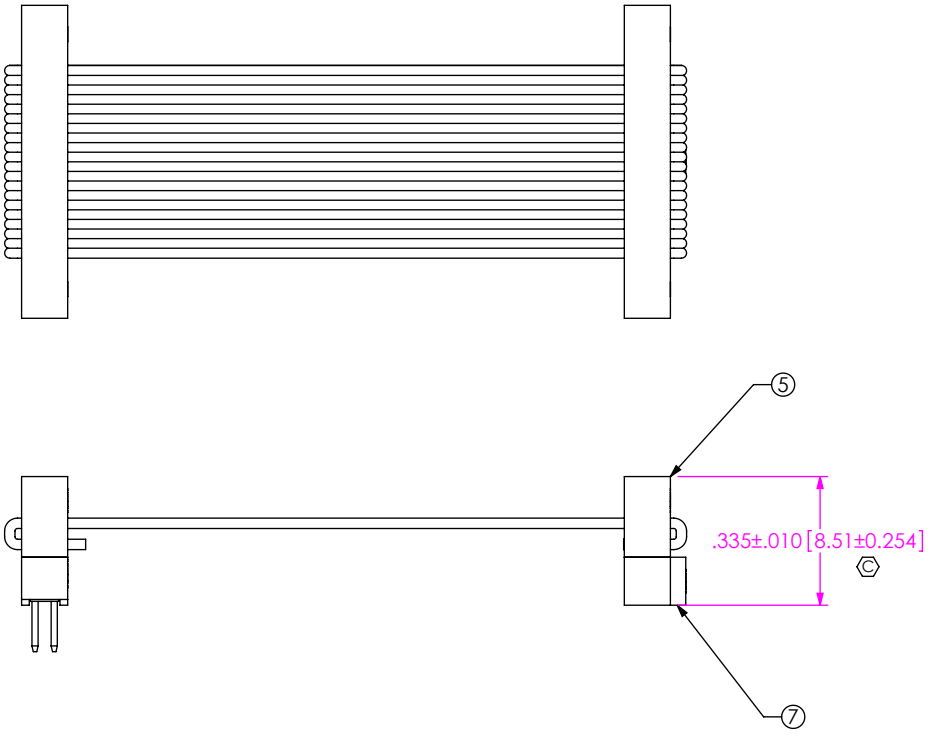

**FIG 17**  
 (FFMD-25-T-XX.XX-01-X-N-SR SHOWN)  
 (SAME AS FIG 1 AND FIG 16, DIFFERENT AS SHOWN)  
 (FOR POSITIONS 16-25 ONLY)  
 \*NOT RELEASED FOR PRODUCTION

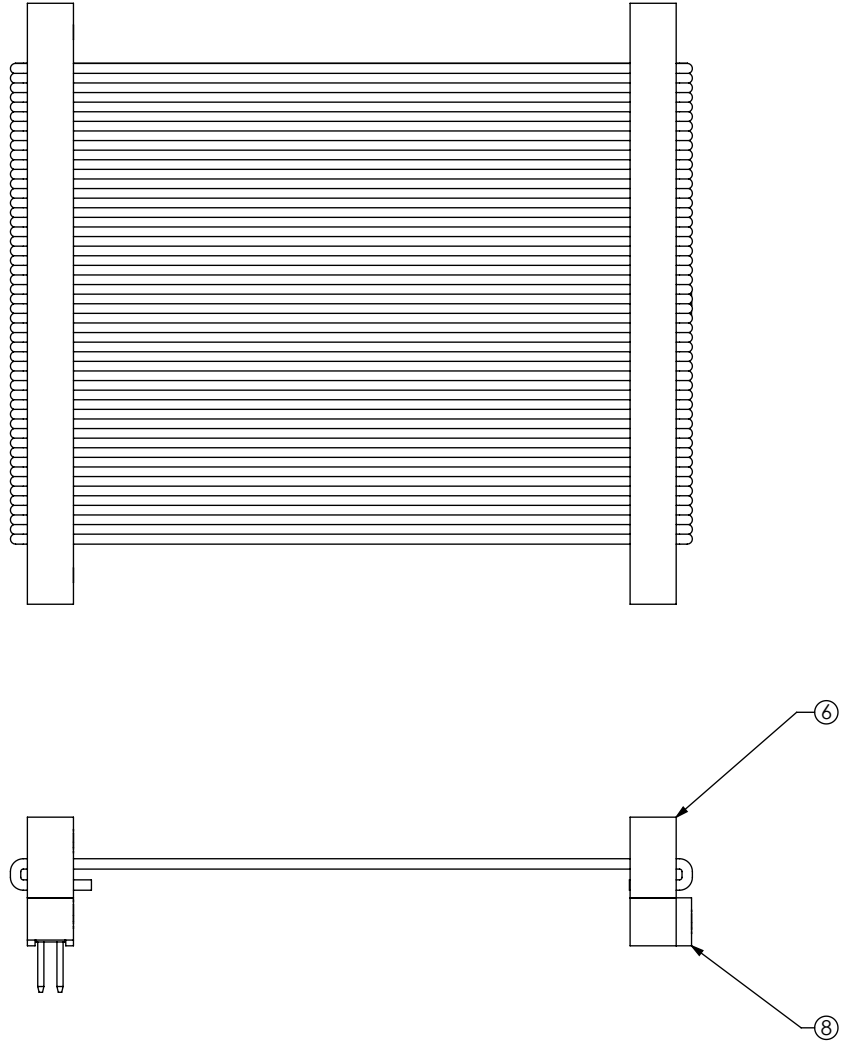

**PROPRIETARY NOTE**  
 THIS DOCUMENT CONTAINS CONFIDENTIAL AND PROPRIETARY INFORMATION AND ALL DESIGN, MANUFACTURING, REPRODUCTION, USE, PATENT RIGHTS AND SALES RIGHTS ARE EXPRESSLY RESERVED BY SAMTEC, INC. THIS DOCUMENT SHALL NOT BE DISCLOSED, IN WHOLE OR PART, TO ANY UNAUTHORIZED PERSON OR ENTITY NOR REPRODUCED, TRANSFERRED OR INCORPORATED IN ANY OTHER PROJECT IN ANY MANNER WITHOUT THE EXPRESS WRITTEN CONSENT OF SAMTEC, INC.

DO NOT SCALE DRAWING  
 SHEET SCALE: 2:1



520 PARK EAST BLVD, NEW ALBANY, IN 47150  
 PHONE: 812-944-6733 FAX: 812-948-5047  
 e-Mail: info@SAMTEC.com code: 55322

DESCRIPTION:  
 .050 X .050 DOUBLE ROW MALE IDC CABLE ASSEMBLY

DWG. NO.  
**FFMD-XX-X-XX.XX-01-X-X-XXX**

BY: T NEWTON 02/15/2008 SHEET 5 OF 6

FEND VIEW SHOWN WITH  
FMC-XX-D REMOVED

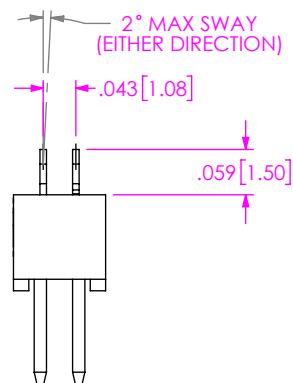
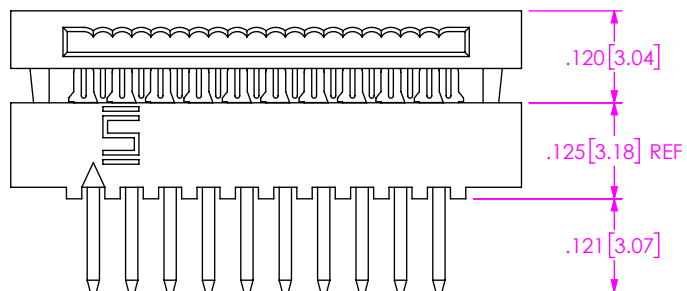

• PROPRIETARY NOTE •  
THIS DOCUMENT CONTAINS CONFIDENTIAL AND PROPRIETARY INFORMATION AND ALL DESIGN, MANUFACTURING, REPRODUCTION, USE, PATENT RIGHTS AND SALES RIGHTS ARE EXPRESSLY RESERVED BY SAMTEC, INC. THIS DOCUMENT SHALL NOT BE DISCLOSED, IN WHOLE OR PART, TO ANY UNAUTHORIZED PERSON OR ENTITY NOR REPRODUCED, TRANSFERRED OR INCORPORATED IN ANY OTHER PROJECT IN ANY MANNER WITHOUT THE EXPRESS WRITTEN CONSENT OF SAMTEC, INC.

DO NOT SCALE DRAWING  
SHEET SCALE: 2:1

**samtec**  
520 PARK EAST BLVD, NEW ALBANY, IN 47150  
PHONE: 812-944-6733 FAX: 812-948-5047  
e-Mail: info@SAMTEC.com code: 55322

DESCRIPTION:  
.050 X .050 DOUBLE ROW MALE IDC CABLE ASSEMBLY  
DWG. NO.  
FFMD-XX-X-XX.XX-01-X-X-XXX  
BY: T NEWTON 02/15/2008 SHEET 6 OF 6